



6.88"

- **UL®1449 Listed Edition 5.0**
- **Type 1 SPD, 20kA In**
- **320kA 8/20µs I_{max} surge rating per phase**
- **Two Stage SPD with backup protection**
- **NEMA 4X**
- **UL® 50E Type 4 Enclosure**
- **All modes protected**
- **Optional Recessed Mounting Trim Plate**
- **Prewired 36" leads for alarm contacts**
- **Audible Alarm (including phase loss)**
- **Versatile Range of Applications**
- **Ten Year Limited Warranty**

Model	Voltage
SP320S12	S120/240V 3w+G
SP320Y12	Y120/208V 4w+G
SP320Y24	Y277/480V 4w+G
SP320D2	240V 3ph Delta
SP320D4	480V 3ph Delta
SP320D12	120/240V 3ph Delta

The **OMEGA POWER SP320** Series is a Two stage Suppressor that provides full protection, even if a lightning strike should damage or disable Stage one.

The **SP320** is **UL® 1449 Edition 5** Listed as an SPD for **Type 1** or **Type 2** locations. Type 1 allows for installation on the line or load side of the service panels and fusing and/or circuit breakers are optional. With a **320 kA per phase** surge rating, the SP320 is well suited for high exposure locations.

Applications include service entrance, distribution switchgear, branch panels, Motor Control Centers (MCC), lighting panels, HVAC, and much more.

The SP320 provides economical protection against damaging transients and surge currents. With a NEMA 4X enclosure rating this product is well suited for outdoor applications. Engineered to provide durability and long life, even under the most adverse conditions.

UL®1449 Listed Edition 5.0
(Type 1), CE, CSA, IEC 6143-1

SP320

SP320 SPECIFICATIONS COMMON TO ALL VOLTAGES

Max Discharge Current, I_{max}	320kA 8/20 μ s per phase (I_{max})
Nominal Discharge Current, I_n	20kA 8/20 μ s / mode
Protection Modes	ALL MODES
Short Circuit Current Rating	200kAIC
Status / Alarm	2 Green LED status indication per phase / AUDIBLE ALARM
Dimensions	6.88”h x 2.97”d x 6.88”w
Enclosure / Rating	Polycarbonate / NEMA 4X / UL 50E, Type 4
Connection	(36” of # 10 AWG) flying leads, 3/4” Liquid Tight Cable Gland
Mounting	3/4” straight nipple.
Approvals	UL® 1449 LISTED EDITION 5.0 (TYPE 1), CE, CSA, IEC 6143-1
Complies With	ANSI/IEEE: C62.41.2 -2002, C62.41.1-2002, C62.45-2002 CAT A, CAT B, CAT C
Temperature	- 40 to 185 F
Unit Weight	2.4 lb
Recessed Wall	Optional Flush Mounting Plate for Drywall
Warranty	10 Years Limited Free Replacement

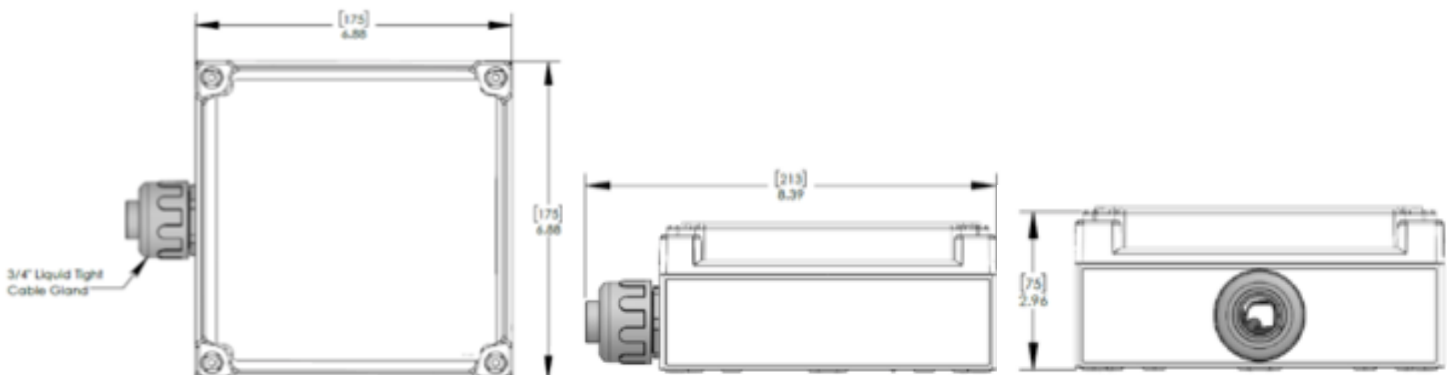

SP320

SP320 SPECIFICATIONS MULTI PHASE

Model	SP320S12	SP320Y12	SP320Y24
Nominal System Voltage, Un	120/240 V	120/208 V	277/480 V
Distribution System	Split phase 3W+G	3 Ph Y 4W+G	3 Ph Y 4W+G
MCOV	180/360 VAC	150/300 VAC	350/700 VAC
VPR Voltage Protection Rating L-N	L-L 1200 V	L-L 1000 V	L-N 1200 V
VPR Voltage Protection Rating L-G	L-N 700 V	L-N 600 V	L-G 1200 V
VPR Voltage Protection Rating N-G	L-G 800 V	L-G 700 V	N-G 1000 V

SP320 SPECIFICATIONS 3 PHASE DELTA

Model	SP320D2	SP320D12	SP320D4
Nominal System Voltage, Un	240 V	120/240V hileg delta	480 V
Distribution System	3 Ph Delta, 3W +G	3 phase 3W+G	3 Ph Delta 3W+G
MCOV	275 VAC	180/275 VAC	550 VAC
VPR Voltage Protection Rating L-L	L-L 1500 V	L-N 1200 V / 1500 V	L-L 3000 V
VPR Voltage Protection Rating L-N	L-G 900 V	L-G 800 V / 900V	L-G 1500 V
VPR Voltage Protection Rating L-G		N-G 700 V	

