

Installation Instructions

SAFETY INSTRUCTIONS

This product must be:

- Installed by an electrically qualified person.
- Installed in accordance with applicable National Standards, Codes, and Practices (for example, IEC 60364-4-44, IEC 60364-5-53, IEC 61643-12, etc).
- Suitably fused as shown, but always deferring to applicable National Standards, Codes, and Practices.
- Used within its ratings. In particular, the connected voltage must not exceed Uc.
- Used only as intended, and in accordance with these instructions. It must not be tampered with.
- Checked for external physical damage and that the status indicator is Green. If damage is found, or the indicator is Red, the product must not be installed.

Installationsanleitung

SICHERHEITSHINWEISE

Dieses Produkt muss:

- von einer Elektrofachkraft installiert werden.
- in Übereinstimmung mit den geltenden nationalen Standards, Normen und Praktiken (z. B. IEC 60364-4-44, IEC 60364-5-53, IEC 61643-12 usw.) installiert werden.
- wie gezeigt, geeignet abgesichert sein, aber immer den geltenden nationalen Standards, Normen und Praktiken entsprechend.
- seiner Auslegung entsprechend genutzt werden. Insbesondere darf die angeschlossene Spannung die Spannung Uc nicht überschreiten.
- wie beabsichtigt und gemäß dieser Anleitung verwendet werden. Es darf nicht manipuliert werden.
- auf äußere physische Beschädigung geprüft werden und die Statusanzeige muss grün sein. Wenn Beschädigungen festgestellt werden oder die Anzeige rot ist, darf das Produkt nicht installiert werden.

Instructions d'installation

CONSIGNES de SECURITE

Ce materiel doit etre:

- Installé par une personne qualifiée en électricité.
- Installé en conformité avec les normes nationales applicables, codes et pratiques (par exemple IEC60364-4-44, IEC 60365-5-53, IEC 61643-12, etc.)
- Convenablement protégé par des fusibles comme indiqué, mais toujours se reporter aux normes nationales applicables, codes et pratiques.
- Utilisé suivant les valeurs du produit. En particulier, la tension connectée ne doit pas dépasser la valeur Uc.
- Utilisé uniquement comme prévu, et en conformité avec ces instructions. Il ne doit pas avoir été altéré.
- Contrôlé dans son aspect extérieur (dommages extérieures) et que l'indicateur de statut soit vert. Si un dommage est trouvé ou que l'indicateur de statut est rouge, le produit ne doit pas être installé.

Instrucciones de instalación

INSTRUCCIONES DE SEGURIDAD

Este producto debe ser:

- Instalado por una persona calificada.
- Instalado en conformidad con las normas y prácticas locales vigentes (por ejemplo, IEC 60364-4-44, IEC 60364-5-53, IEC 61643-12, etc.)
- Cableado adecuadamente como se indica en estas instrucciones, y en conformidad con las normas y prácticas locales vigentes.
- Usado dentro de sus limitaciones. En particular, el voltaje conectado no debe exceder Uc.
- Usado solo como es previsto y en conformidad con estas instrucciones. El producto no debe ser adulterado.
- Inspeccionado para verificar que no tenga daño en su exterior y que la luz del indicador esté verde. Si tiene algún daño, o la luz del indicador está roja, el producto no debe ser utilizado.

Istruzioni di installazione

ISTRUZIONI DI SICUREZZA

Questo prodotto deve essere :

- Installato da una persona qualificata.
- Installato in conformità delle norme/standards Nazionali (Esempio, IEC 60364-4-44, IEC 60364-5-53, IEC 61643-12, etc).
- Stato SPD come indicato, sempre in conformità delle norme Nazionali applicabili.
- Usato entro il suo ratings. In particolare, la tensione collegata non deve superare Uc.
- Utilizzato solo come previsto e in conformità a queste istruzioni. Non deve essere manomesso.
- Controllato per danni fisici esterni e che l'indicatore di stato è verde. Se si verifica un danno o l'indicatore è Rosso, il prodotto non deve essere installato.

OMEGA
POWER 

DTB1xR
DTB2xR
DTB3xR
DTB4xR

Omega Power

Systems, Inc.
PO Box 406
Port Salerno, FL 34992
772-219-0045

DANGER

1. Electrical Shock or Burn Hazard. Failure to lockout electrical power during installation or maintenance can result in Fatal Electrocutation, Severe Burns, or other Injuries.
2. Prior to installation, ensure the product is of the correct voltage, current, phasing, and frequency for the intended power distribution system.
3. This unit must be installed on the load side of the main over-current protection.
4. Diagrams are for reference only. Schematics are representative of typical applications and are only to be used for reference.

CAUTION





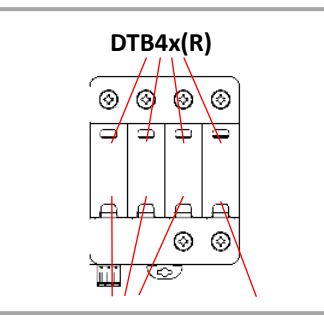
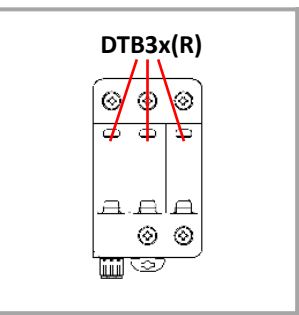
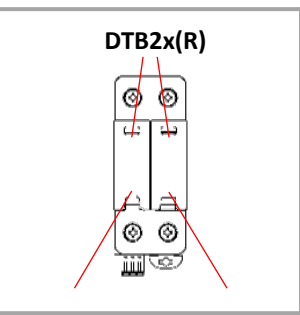
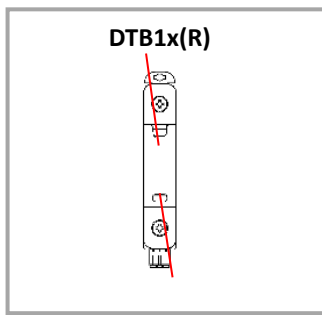

1. The ground (earth) terminal must be connected to a low impedance earth (< 10 ohms) for correct operation.
2. Ungrounded power systems are inherently unstable and can produce excessively high line-to-ground voltages during certain fault conditions. During these fault conditions any electrical equipment, including an SPD, may be subjected to voltages which exceed their designed ratings. This information is being provided to the user so that an informed decision can be made before installing any electrical equipment on an ungrounded power system.

UL1449 and US Requirements

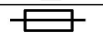
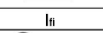
1. This product has Type 1CA UL1449 Edition 5 approval, and may be permanently installed after the service transformer either on the line side or the load side of the service equipment overcurrent device.
2. UL1449 Short Circuit Current Rating up to 200kA
3. This product must be installed in accordance with the National Electrical Code, ANSI/NFPA-70 (NEC).
4. The fusing information on the reverse side of this sheet is intended for IEC (not NEC) compliant installations.

DTB	modules	x = Voltage	(R) Alarm
	1x = 1+V 2x = 2+V 3x = 3+V 4x = 4+V	150 = 1 300 = 2 350 = 3 480 = 4	R = 

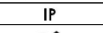

IEC 61643-11	
	Class II
	≤ 315A gG (I _{SCCR} ≤ 25 kA) ≤ 250A gG (I _{SCCR} ≤ 50 kA)
	100 Arms
	-40 °C to +85 °C
	5%...95% RH
	≤ 2000 m ≤ 6562 ft
	20
	I _{PE} ≤ 0.6 mA

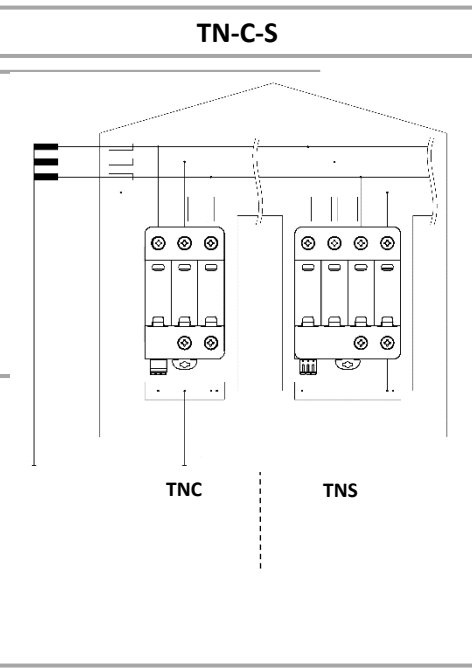
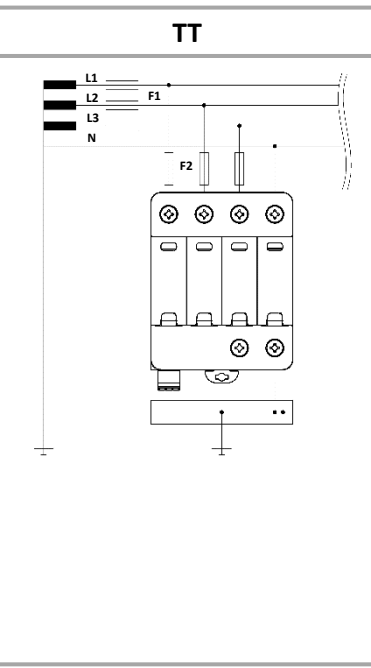
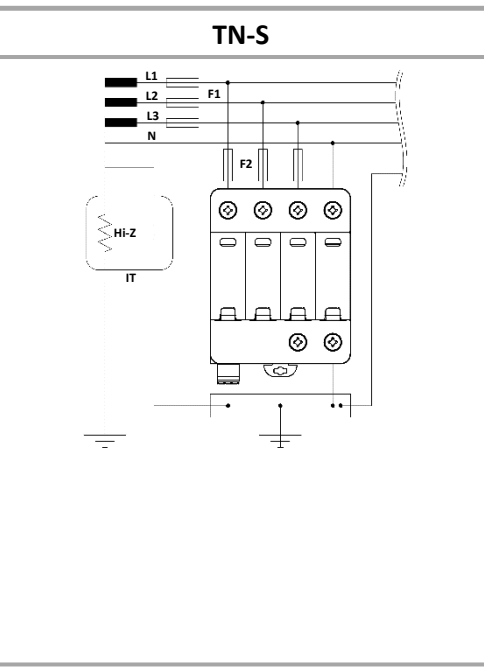
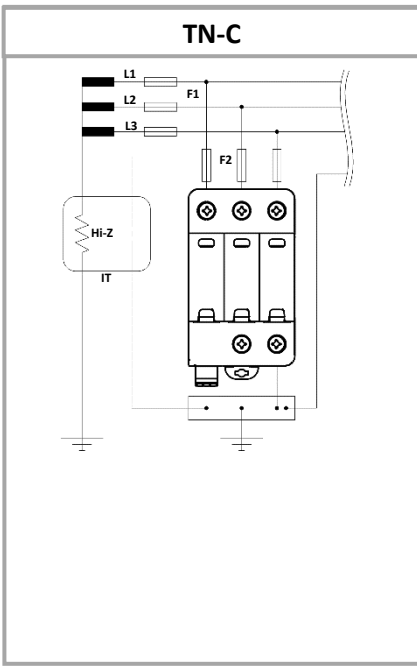

IEC/EN

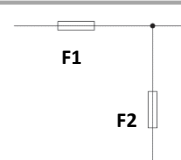

The minimum distance of the SPD from any earthed conductive surface at which the SPD can be installed is 0mm.

I _{SCCR} ≤ 25 kA	I _{SCCR} ≤ 50 kA
F1 ≤ 315A gG	F1 ≤ 250A gG
F2	F2
F1 > 315A gG	F1 > 250A gG
↓	↓
F2 = 125A gG	F2 = 125A gG

