

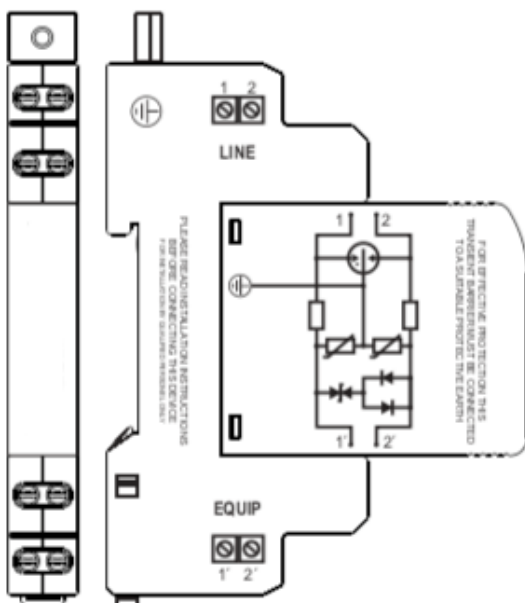

Installation Instructions:

1. Ensure that power is removed from the area and the circuits to be connected.
2. Connect line side wiring to the DD screw terminals marked LINE (1, 2, 3, 4). The LINE side of the DD is the exposed side where the surge is expected to originate.
3. Connect equipment side wiring to the DD screw terminals marked EQUIP (1', 2', 3', 4'). The EQUIP side of the DD is the protected side and wires to the equipment being protected.
4. The DD should be installed as close to the equipment being protected as possible. Where protecting long cable runs (> 30 meters), a DD unit should be installed at either end of the cable.
5. Connect the DD's ground screw terminal to a low impedance ground using as direct a path as possible. This "ground" should also be referenced to the equipment being protected. When the DD is installed on a DIN rail, grounding of the unit can be achieved by connecting the rail to ground.

DD SP Electrical Connection



Signal Pair protection, via terminals LINE side 1, 2 and EQUIP side 1', 2'. Grounding via ground tab or DIN rail.

DD DP Electrical Connection

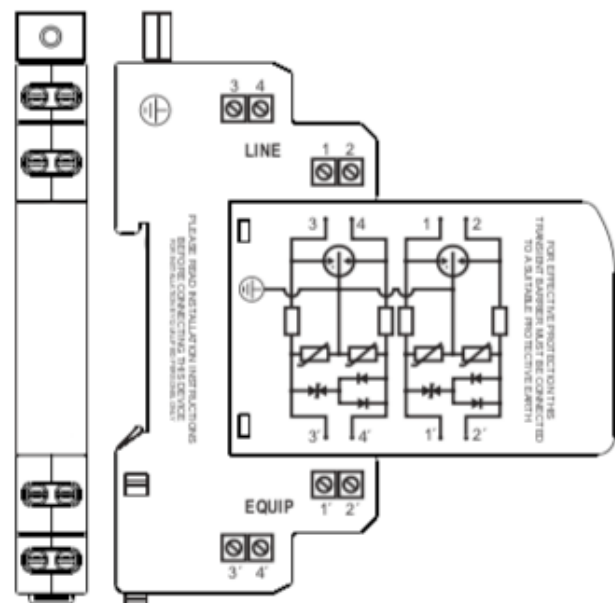

Dual (2) Pair protection, via terminals LINE side 1, 2 and 3, 4 and EQUIP side 1', 2', 3', 4' respectively. Grounding via ground tab or DIN rail.

Maintenance: Failure of DD is usually indicated by interruption of data or a fault on the signal (control) line. The DD has been designed for simple plug-in modular replacement, without the need to disturb circuit wiring. Before removing a module from service, ensure that the power has been removed and if possible "locked out". Qualified personnel should only undertake replacement of modules. Replacement plug-in modules are available. Ensure that the new module is of the same type and voltage as that being replaced.

Danger: Electrical shock or burn hazard. Installation of this SPD should only be made by qualified personnel. Failure to lockout electrical power during installation or maintenance can result in fatal electrocution, or other injuries. Before working with or making any connections to this electrical panel, be sure that power has been removed from all associated wiring, electrical panels, and other electrical equipment.